

# TELLUS R/W

Tellus R/W is a task light designed specifically for vehicle and applications where night vision is of great importance. Such applications can be a ship bridge or a train cab.

The lamp head is made from durable aluminium and the sturdy flexible arm allows for accurate adjustment of the lamp head position yet maintaining good vibration resistance.

The light colour can easily be switched between white and red light, the built-in dimming function allows for precise adjustment of the light intensity, down to approximately 2 % intensity. Tellus R/W has an extended shade for protection against glare and provides a focused light pattern. Supply voltage is SELV 12-24 V for direct connection in vehicles and similar applications, adaptor for connection to the power net is available as an accessory.

The supply voltage is SELV 12–24 V for direct connection in vehicles and similar applications. An adapter for connection to the mains is available as an accessory.

Customized versions are available.

## Features

- Flexible arm
- LED service life >30000 h
- 12-24 V AC/DC supply voltage
- Red and white light colour
- Dimmable

## Applications

- Ship bridges
- Train cabs
- Road going vehicles

## Benefits

- Low power consumption
- Very low heat emission
- Switchable between red and white light colour
- Flexible arm for accurate adjustment
- M12 connector





### Technical specifications

Supply voltage	12-24 V AC/DC (Accessory 230 V AC/DC-adapter)
Connection cable	Standard 1,9 m H05VV-F
Connector	M12 (Male) 4-pin A-code
Power consumption	5 W
Arm length	500 or 700 mm
Colour	Black
Colour temperature	6500 K / Red 630 nm
IP-rating	IP20, IP43
Protection class	III
Beam angle	45°
Light output	77 Lm, White, 600 Lx at 500 mm distance. Red, 150 Lx at 500 mm distance
Colour rendering index	CRI: 80 (6500 K)
EMC	EN 55015: 2019 + A11:2020, EN 60533:2015 (Bridge)
Weight	1,5-1,7 kg
Technical lifespan	>30000 h

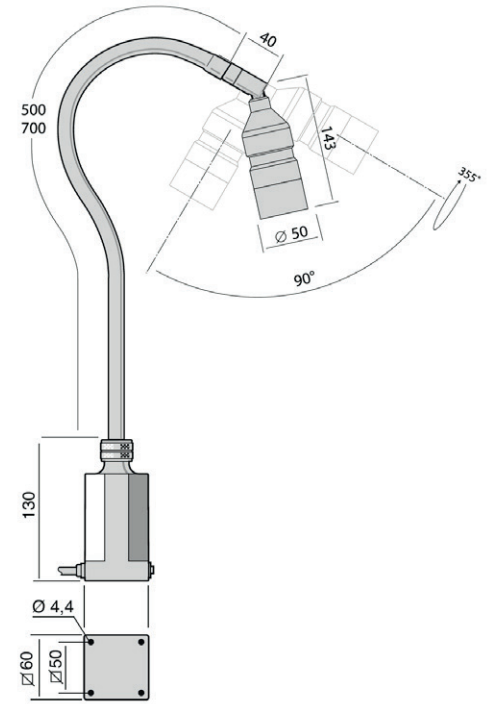
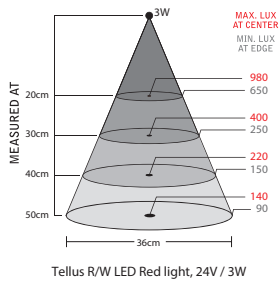
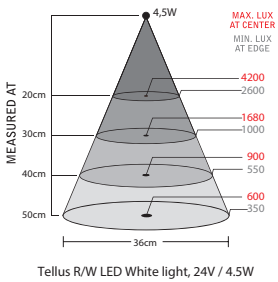

Arm	Connection	Version	Part no.
500 mm	12-24 V AC/DC	IP43	34500
500 mm	12-24 V AC/DC	IP20, Joint	34510
700 mm	12-24 V AC/DC	IP43	34520
700 mm	12-24 V AC/DC	IP20, Joint	34530

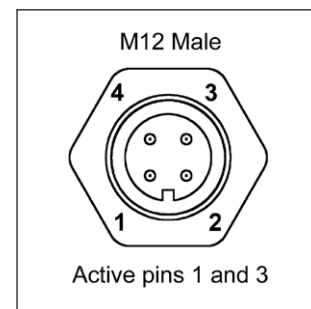

**Accessories**

Plugin Adapter 220-240 V 33920	Magnetic base 14000	Table base 14015	C-clamp 14020	Wall mount 14030

## ACCESSORIES AND SPARE PARTS



Accessories		Suitable for	Info	Part no.
<b>Lens/Glass</b>		Tellus R/W	Clear	15402
		Tellus R/W	Frosted (std)	15112
		Tellus R/W	Red	15114
		Tellus R/W	Green	15110
<b>C-clamp</b>		All with std. base	Max 42 mm	14020
		M4 x 20 (4x) included		
<b>Magnetic base</b>		Tellus/Lumius/Pluto/LS	Ø 90 mm	14000
		M4 x 20 (4x) included		
<b>Wall mount</b>		All with std. base	50 x 80 mm	14030
		M4 x 20 (4x) included		
<b>Table base</b>		All with std. base	Ø 200 mm	14015
		4.0 x 25 (4x) included		
<b>Connector</b>		All LED lighting	M12 Male	18952
		All LED lighting	M12 Female	31301
<b>AC/DC-Adapter</b>		Pluto/Tellus/Solus6/Solus9/ Lumius/LS/CL-LED/Luxor (Euro)	Plugin Adapter Europé 220-240 V Max 15 VA, IP44	33920
		Pluto/Tellus/Solus6/Solus9/ Lumius/LS/CL-LED/Luxor (UK)	Plugin Adapter UK 220-240 V Max 15 VA, IP44	33921
		Pluto/Tellus/Solus6/Solus9/ Lumius/LS/CL-LED/Luxor (US)	Plugin Adapter US 100-120 V Max 15 VA, IP44	33922