

SUNMACH 10

Sunmach 10 is a versatile LED task light for industrial applications and harsh environments. Typical applications are lighting for machining industry and inspection.

LED-technology delivers low energy consumption and long service life as well as high vibration durability and virtually no radiated heat in the light beam.

Fitted with an 36° beam angle, IP65 dust and water protection. Handle and switch on the lamp head.

The aluminum lamphead and rugged arm make it usable in a variety of industrial and professional environments. It can be supplied with an external plugin adaptor for 230 V, the adapter's protection class is IP44.

Custom versions available upon request.

Features

- Arm length 500 mm with rotational swivel joint
- IP65
- 12-24 V AC/DC
- AC/DC-Adaptor 220-240/24 V IP44, available as accessory

Applications

- Industrial applications
- Machining industry
- Inspection & reading

Benefits

- Low power consumption
- Low heat emission
- Sturdy lamp head in aluminum
- Flexible arm for precise adjustment
- M12 connector





Technical specification

Supply voltage	12-24 V DC (Accessory 230 V AC/DC-adapter)
Connection cable	Standard 1,9 m H05VV-F
Connector	M12 (Male) 4-pin A-code
Power consumption	10 W
Arm length	500 mm
Colour	Black
Colour temperature	5000 K
IP rating	IP65
Protection class	III
Beam angle	36°
Light output	800 Lm, 7500 Lx at 500 mm distance
Colour rendering index	83
Weight	0,8 kg
Technical lifespan	>25000 h

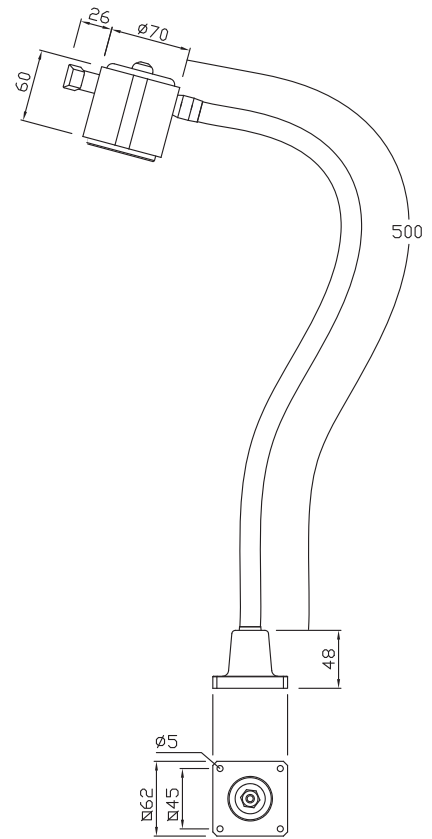
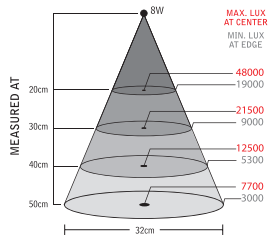

Arm	Connection	Version	Part no.
500mm	12-24V AC/DC	IP65	31270

