

SOLUS 9

The Solus 9 is a high-intensity LED Task Light with light intensity comparable to that of a conventional 50W halogen light source. The energy consumption is significantly lower saving approximately 85% compared to halogen.

Standard features include dimmer functionality and IP65 rating on low voltage models making the product suitable for a wide variety of applications. The Sunnex flexible gooseneck provides vibrationresistant positioning and the LED light source emits virtually no heat.

Custom versions available.

Features

- Up to 36000Lux light output at 500mm
- Low energy consumption
- Colour Rendering Index (CRI) of 92 making the light suitable for colour-critical applications
- IP20, IP65
- Dimmer switch in the durable aluminium lamp head

Applications

- Targeted at industry customers who needs task light with focused light intensity
- For customers with specific need of dimming in the high intensity segment

Benefits

- Flexible gooseneck arm for easy positioning
- Articulated arm system for long reach
- Rugged design
- High quality
- M12 connector





Technical specifications

Supply voltage	12-24 V AC/DC (Accessory 230 V AC/DC-adaptor)
Connection cable	Standard 1,9 m H05VV-F
Connector	M12 (Male) 4-pin A-code
Power consumption	6 W
Arm lenght	500, 700, 1000, 1250 mm or Spot
Colour	Black
Colour temperature	4000 K
IP-rating	IP20 or IP65
Protection class	III
Beam angle	10° standard. 25° and 40° available as accessory
Light output	390 Lm, 39500 Lx at 500 mm distance (10°)
Colour rendering index	CRI: 92
Weight	1,6-2,5 kg
Technical lifespan	>50000 h
Dimmer	Standard

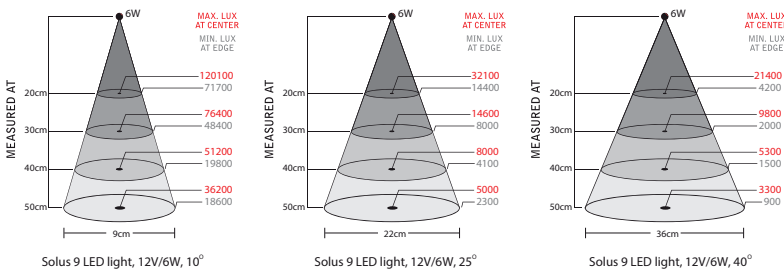

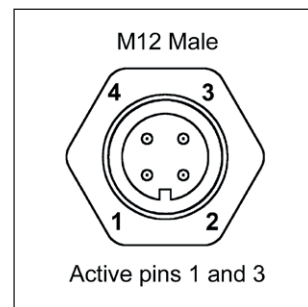
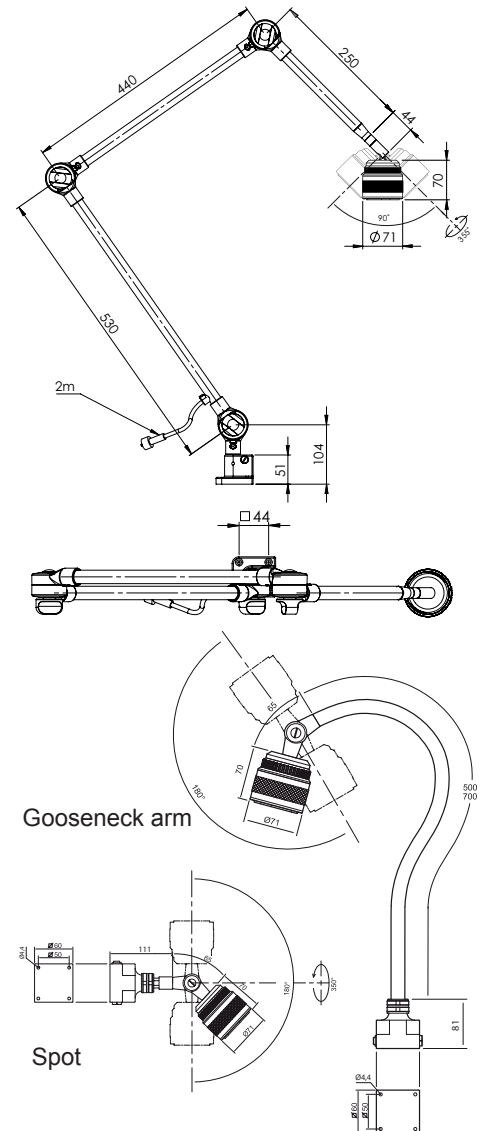

Arm	Connection	Optics	Version	Part No
500 mm	12-24 V AC/DC	10°	IP65	33310
500 mm	12-24 V AC/DC	25°	IP65	33310-25
700 mm	12-24 V AC/DC	10°	IP65	33330
700 mm	12-24 V AC/DC	25°	IP65	33330-25
1000 mm AAS	12-24 V AC/DC	10°	IP20	33355
1000 mm AAS	12-24 V AC/DC	25°	IP20	33355-25
1250 mm AAS	12-24 V AC/DC	10°	IP20	33353
1250 mm AAS	12-24 V AC/DC	25°	IP20	33353-25
Spot	12-24 V AC/DC	10°	IP20	33360
Spot	12-24 V AC/DC	25°	IP20	33360-25



Accessories

Plugin Adapter 220-240 V 33920	Magnetic base 12010	Table base 14015	C-Clamp 14020	Wall mount 14030

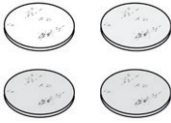

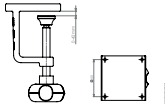
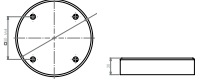
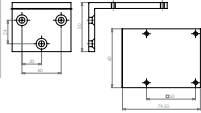
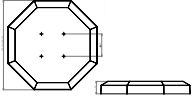
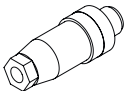
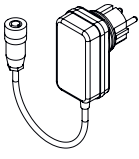
Accessory		Suitable for	Info	Part. no.
Lens/Glass		Solus 6 / Solus 9	Clear (std)	18004
		Solus 6 / Solus 9	Frosted	18005
Optics		Solus 6 / Solus 9	15°	33910
		Solus 6 / Solus 9	25°	33925
		Solus 6 / Solus 9	40°	33940
C-Clamp		All with std. base M4 x 20 (4x) included	Max 42 mm	14020
Magnetic base		Luxor/Solus6/Solus9/LS M4 x 20 (4x) included	Ø 110 mm	12010
Wall mount		All with std. base M4 x 20 (4x) included	50 x 80 mm	14030
Table base		All with std. base 4.0 x 25 (4x) included	Ø 200 mm	14015
Connector		All LED lighting	M12 Male	18952
		All LED lighting	M12 Female	31301
AC/DC-Adaptor		Pluto/Tellus/Solus6/Solus9/ Lumius/LS/CL-LED/Luxor (Euro)	Plug Adapter Europé 220-240 V Max 15 VA, IP44	33920
		Pluto/Tellus/Solus6/Solus9/ Lumius/LS/CL-LED/Luxor (UK)	Plug Adapter UK 220-240 V Max 15 VA, IP44	33921
		Pluto/Tellus/Solus6/Solus9/ Lumius/LS/CL-LED/Luxor (US)	Plug Adapter US 100-120 V Max 15 VA, IP44	33922