

LUXOR

Sunnex Luxor is a LED-lamp with exceptional intensity for machine applications, where the lamp head is placed at a distance from the lit surface. The lamp head is made from durable aluminium for challenging environments. The classic Sunnex flexible arm and Spot-version can be chosen or the articulated arm system, for superior reach.

The wattage is 12 W and suitable distance between lamp head and surface is 75-200 cm, with narrow beam (8°) the distance can be increased to 350 cm. Supply voltage is 24 V DC for safe use in, e.g. industrial environment, adaptor for connection to the power net is available as an accessory. IP20 and IP65 versions are available as standard.

Suitable applications are larger machines, CNC-centres and other applications where very high intensity is needed.

If spot or flexible arm is chosen our accessories like C-clamp, wall bracket, magnetic base and table base can be used with this product. 230 V adaptor is also an accessory.

Custom versions available.

Features

- Flexible arm, articulated arm system AAS or Spot-version
- Long technical life >50000 h
- 24 V DC supply voltage for safe use in harsh environments
- High intensity for use at greater distance
- Adaptor available for direct connection to mains voltage

Applications

- Machines
- CNC-centres
- Large presses
- Other applications where high intensity is required

Benefits

- Low power consumption
- Very low heat emission
- Very high intensity and luminous output
- Flexible arm for precise adjustment
- Articulated arm system for superior reach
- Cool white light color with a high color rendering index provides ergonomically correct lighting
- M12 Connector





Technical specifications

Supply voltage	24-36 V DC (Accessory 230 V AC/DC-adapter)
Connection cable	Standard 1,9 m H05VV-F
Connector	M12 (Male) 4-pin A-code Pin 1 (+) Pin 3 (-)
Power consumption	12 W
Arm length	500, 1000, 1250 mm or spot
Colour	Black
Colour temperature	4300 K
IP-rating	IP20 or IP65
Protection class	III
Beam angle	17° standard. 8° as option.
Light output	900 Lm, 4400 Lx 17° std. 23000 Lx in 8° design at 1 m distance
Colour rendering index	CRI: 95
Weight	0,8-2,2 kg
Technical lifespan	>50000 h

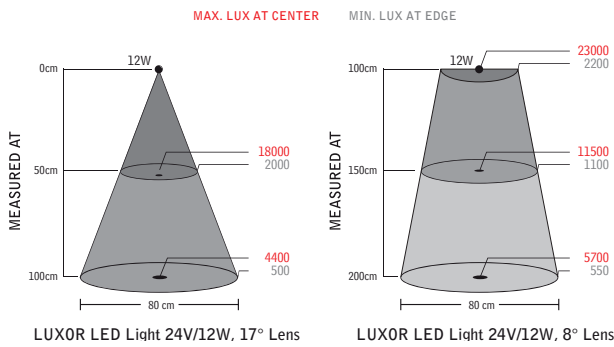

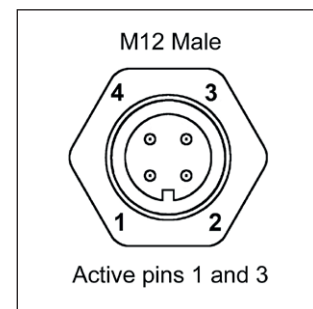
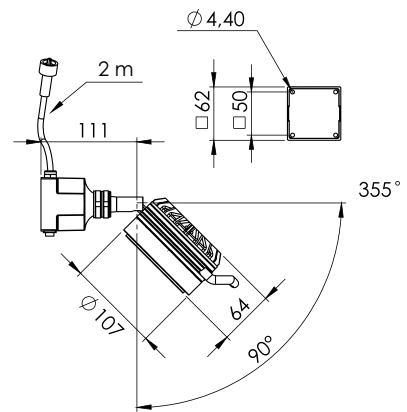
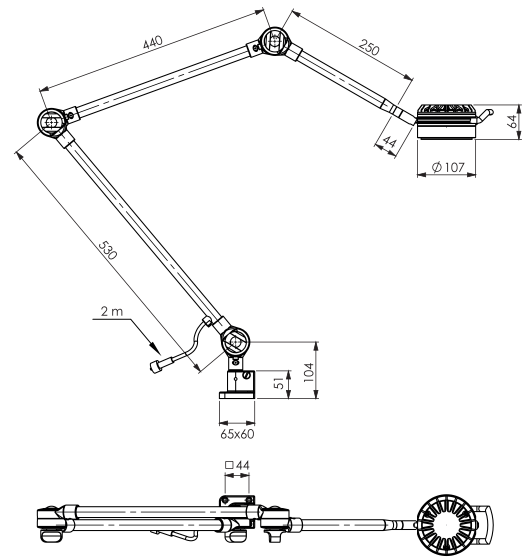

Arm	Connection	Version	Part.No.
500 mm	24-36 V DC	IP65	36100
500 mm	24-36 V DC	IP20, Joint	36110
Spot	24-36 V DC	IP20	36160
AAS two sections	24-36 V DC	IP65	36155
AAS three sections	24-36 V DC	IP65	36153



Accessories

Plugin Adapter 220-240V 33920	Magnetic base 12010	Table base 14015	C-clamp 14020	Wall mount 14030

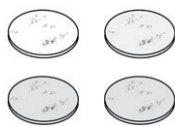

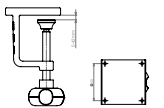
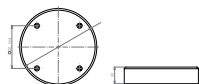
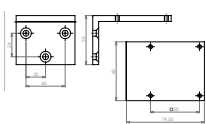
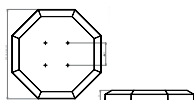
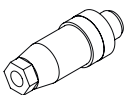
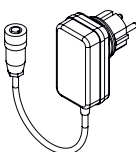
Accessory		Fits model	Info	Art. nr
Lens/Glass		Luxor	Clear (std)	13825
		Luxor	Frosted	13826
Optics		Luxor	8°	18922
		Luxor	17° (std)	18943
C-clamp		All with standard foot M4 x 20 (4x) included	Max 42 mm	14020
Magnetic base		Luxor/Solus 6/Solus 9 M4 x 20 (4x) included	Ø 110 mm	12010
Wall mount		All with standard foot M4 x 20 (4x) included	50 x 80 mm	14030
Table base		All with standard foot 4.0 x 25 (4x) included	Ø 200 mm	14015
Connector		All LED lighting	M12 Male	18952
		All LED lighting	M12 Female	31301
AC/DC-Adapter		Pluto/Tellus/Solus6/Solus9/ Lumius/LS/CL-LED/Luxor (Euro)	Plugin Adapter Europé 220-240 V Max 15 VA, IP44	33920
		Pluto/Tellus/Solus6/Solus9/ Lumius/LS/CL-LED/Luxor (UK)	Plugin Adapter UK 220-240 V Max 15 VA, IP44	33921
		Pluto/Tellus/Solus6/Solus9/ Lumius/LS/CL-LED/Luxor (US)	Plugin Adapter US 100-120 V Max 15 VA, IP44	33922