

# LUMIUS

Lumius-series is a state of the art product for demanding applications in various environments. Light fixtures within the series can be fitted with narrow to wide beam optics, making them suitable for a variety of applications from machine tools to workbenches and vehicles. Lumius has the latest LED-technology with high performance in both intensity and quality of light pattern, as well as a high colour rendering index of 95. Including features such as low energy consumption and long service life, high vibration durability and virtually no radiated heat from the light beam. The lamp head is made of aluminium which allows for great heat dissipation and superior protection against external impact.

The IP65 version is specifically developed for harsh industrial environments and applications where dust and moisture resistance is vital. Typical applications are grinders, lathes and drilling machines. The products are also suitable for outdoor use. Dimmable version is specifically developed for chart board lighting on ships and other vessels. It can also be used in a number of other applications where dimming range close to zero intensity is important. Typical applications are ship bridges and visual inspection of components.

Lumius can be supplied with an external plugin adaptor for 230 V. The protection class of the adaptor is IP44.

Customized versions are available.

## Features

- Arm length 500, 700 mm and spotlight
- LED Service life >100000 h
- IP20, IP44 and IP65
- Dimmable almost to zero, always starting at low intensity  
12-36 V DC
- AC/DC-Adaptor 220-240/24 V, IP44 available as accessory

## Applications

- Heavy industrial applications
- Vehicles
- Military & Marine applications, (red lens available as accessory)

## Benefits

- Long service life
- High quality components
- Rugged flexible arm
- High quality light pattern
- Durable design
- High colour rendering
- M12 Connector

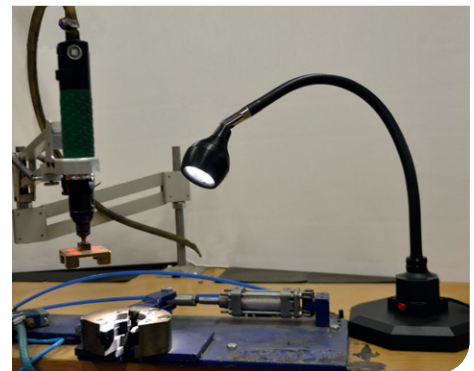



### Technical specification

Supply voltage	12-36 V DC (Accessory 230 V AC/DC-adapter)
Connection cable	Standard 1,9 m H05VV-F
Connector	M12 (Male) 4-pin A-code Pin 1 (+) Pin 3 (-)
Power consumption	4 W
Arm length	500, 700 mm or Spot
Colour	Black
Colour temperature	4300 K
IP rating	IP20, IP44 or IP65
Protection class	III
Beam angle	10° std (25° DIM). 25° or 40° as accessory
Light output	260 Lm, 14400 Lx on 500 mm distance (10°)
Colour rendering index	CRI: 95
Weight	0,8-1,5 kg
Technical lifespan	>100000 h

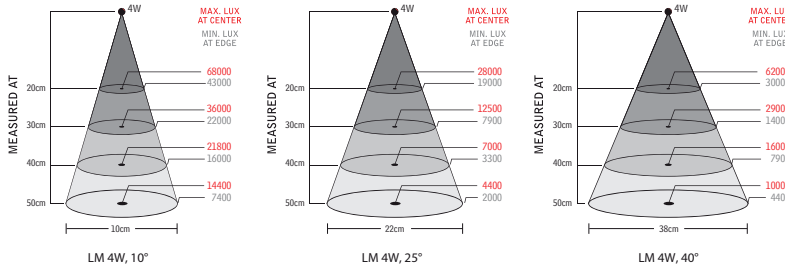

Arm	Connection	Version	Part no.
500 mm	12-36 V DC	IP20	30010
500 mm	12-36 V DC	IP65	30013
500 mm	12-36 V DC	IP44, Dim	30110
500 mm	12-36 V DC	IP20, Joint	30015
500 mm	12-36 V DC	IP20, Joint, Dim	30115
700 mm	12-36 V DC	IP20	30030
700 mm	12-36 V DC	IP65	30033
700 mm	12-36 V DC	IP44, Dim	30130
700 mm	12-36 V DC	IP20, Joint	30035
700 mm	12-36 V DC	IP20, Joint, Dim	30135
Spot	12-36 V DC	IP20, Joint	30011
Spot	12-36 V DC	IP20, Dim	30111

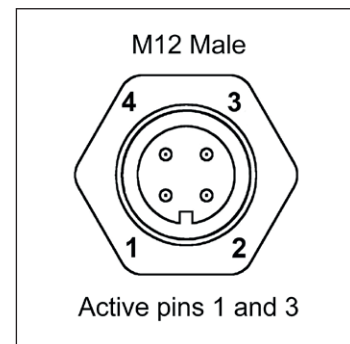
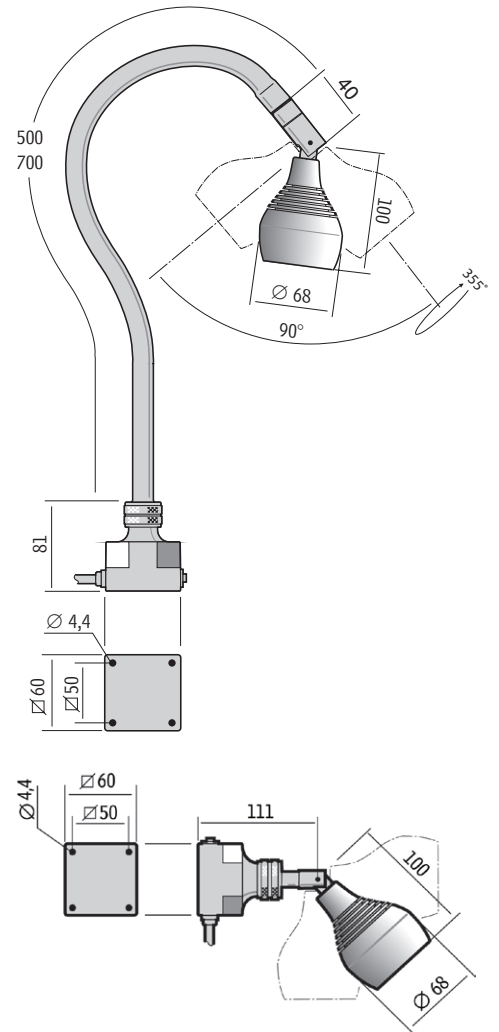

#### Accessories



Plug Adapter 220-240 V  
33920



Magnetic base  
14000

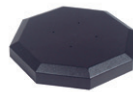

Table base  
14015



C-clamp  
14020



Wall mount  
14030



Accessory		Suitable for	Info	Part. no.
Lens/Glass		Lumius	Clear (std)	18004
		Lumius	Frosted	18005
		Lumius	Red	18831
Optics		Lumius	10° (std)	18878
		Lumius	25° (std DIM)	18879
		Lumius	40°	18880
C-clamp		All with standard foot M4 x 20 (4x) included	Max 42 mm	14020
Magnetic base		Lumius/Tellus/Pluto/LS M4 x 20 (4x) included	Ø 90 mm	14000
Wallmount		All with standard foot M4 x 20 (4x) included	50 x 80 mm	14030
Table base		All with standard foot 4.0 x 25 (4x) included	Ø 200 mm	14015
Connector		All LED lighting	M12 Male	18952
		All LED lighting	M12 Female	31301
AC/DC-Adapter		Pluto/Tellus/Solus6/Solus9/ Lumius/LS/CL-LED/Luxor (Euro)	Plugín Adapter Europé 220-240 V Max 15 VA, IP44	33920
		Pluto/Tellus/Solus6/Solus9/ Lumius/LS/CL-LED/Luxor (UK)	Plugín Adapter UK 220-240 V Max 15 VA, IP44	33921
		Pluto/Tellus/Solus6/Solus9/ Lumius/LS /CL-LED/Luxor(US)	Plugín Adapter US 100-120 V Max 15 VA, IP44	33922